

## FD 9R2-L10

Interruptor de seguridad con retardo mecánico manual serie pesada

### Características Generales

Carcasa:

Metálica, una entrada de PG 13,5

Bloque de contacto:

2NC (B9)

Apertura:

Positiva

Grado de protección:

IP67 de acuerdo con EN60529

Temperatura ambiente:

-25°C a 80°C

Frecuencia de operación:

3600 ciclos / hora

Vida mecánica:

20 millones de operaciones

Corriente térmica (I<sub>th</sub>):

10 Amp

Voltaje máximo de operación:

500 VCA, 600 VCD

Corriente de utilización C.A.:

250V (6 Amp) 400V (4 Amp) 500V (1 Amp)

Corriente de utilización C.D.:

24V (6 Amp) 125V (1.1 Amp) 250V (0.4 Amp)

### Diagrama

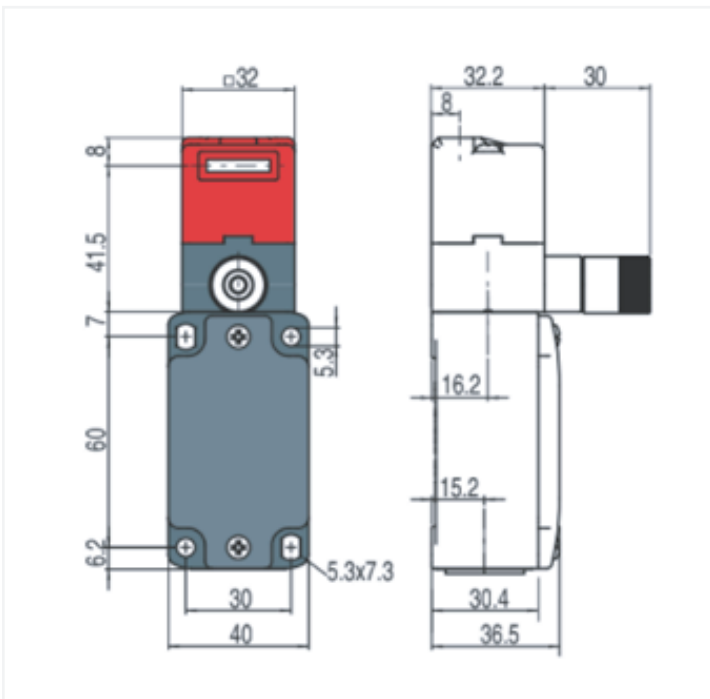

### ACCESORIOS

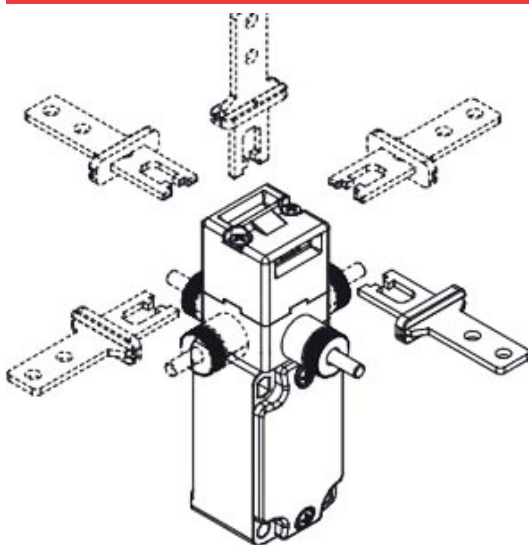

CABEZA ROTATORIA  
EN PASOS DE 90°



VF KEYF



VF KEYF1



VF KEYF2



VF KEYF3



VF KEYF7



VF KEYF8

### Marcas de Calidad

